

POCKET ROCKET®

Wedge-Mount Vibrator

Part # 46000

The *POCKET-ROCKET®* Hopper Car Vibrator, with its urethane shoe wedge bracket, easy-grip handle, and light-weight (27 Lbs), is quiet and extremely portable. The unique urethane shoe bracket eliminates noisy metal to metal contact with the railcar, enabling the unit to operate at less than 82 dBA. The vibrator is not only compact and powerful, but it is highly energy efficient – using only 16 CFM at 90 PSI.

Each POCKET ROCKET comes equipped with:

- ◆ 6 ft Hose Whip
- ◆ Locking Ball Valve w/ Universal Coupling
- ◆ 1 qt VIBRA-LUBE™ Vibrator Oil
- ◆ Filter (5µm), Regulator, Lubricator trio-control.

YOUR COMPLETE HOPPER CAR UNLOADING SOLUTION PROVIDER

The **WORKMASTER** line of unloading products, from our wide selection of gate openers and pneumatic pocket vibrators to our pocket to undertrack conveyor connectors, offers total solutions to the vexing problems of unloading hopper cars. When you call **WORKMASTER**, or one of our dealers, you'll find we're not just product focused – every member of our team is committed to helping you succeed. So whether you need a tool for a specific job or a total unloading system, we'll treat solving your unloading site problem like it is the most important job we have. Because it is !

Other solutions include . . .

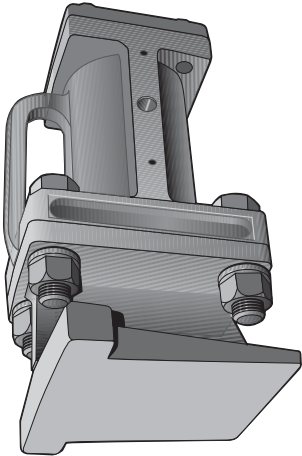

RAIL-SHAKER™ Pocket Vibrator

Opening the hopper car gate presents one set of problems, getting material to flow from the car presents an entirely different problem. But it is no problem with **WORKMASTER's** air driven **Rail-Shaker** wedge-mount pocket vibrator. The assembly's wedge-end fits all standard hopper car pocket female brackets, and its top lugs keep the **Rail-Shaker** from jamming in the pocket. The vibrator pounds the wall of the hopper car like a fast acting sledge hammer, and its high frequency vibration stimulates the material inside to produce instant and consistent flow.

CAR-ROCKER™ Portable Pocket Vibrator

The *Car-Rocker* is a dual roller pneumatic vibrator, ideal for applications that require high frequency and high force. This **WORKMASTER** dual roller vibrator assembly is one of the original heavy-duty vibrators specified for unloading railcars. With only three moving parts (vane, inner and outer rollers), the vibrator has a long wear life and requires little maintenance. Equipped with a comfort grip side handle, the *Car-Rocker* is easily positioned in the pocket or moved from car to car. With two models available, the *Car-Rocker* is guaranteed to energize stubborn material, and promote complete and rapid flow of any material.

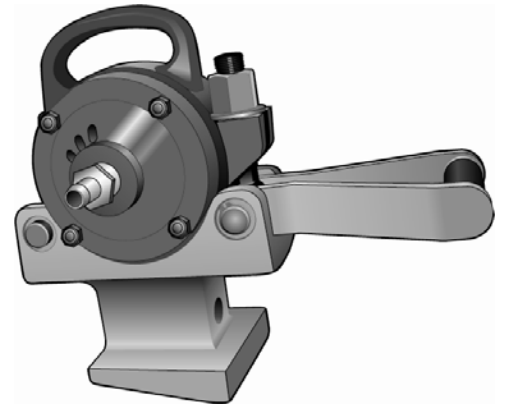

Distributed By:

WORKMASTER®
WE FIND A WAY — OR MAKE ONE!

www.workmaster.net

Ph: 866.476.9217 • Fx: 866.476.9219