

WORKMASTER[®]

WE FIND A WAY — OR MAKE ONE!

GO-A13-HA Gate Opener



MAINTENANCE & PARTS MANUAL

WORKMASTER disclaims any liability for injuries, death or damages arising directly or indirectly, from the use, operation, or application of this product not in accordance with the procedures, specifications and recommendations contained in this owner's manual. The user of this product is responsible to install, maintain and operate the product and parts or components manufactured or supplied by **WORKMASTER** in such a manner as to comply with all federal, state, and local rules, ordinances, regulations, and laws, including the Williams-Steiger Occupational Safety Act, and the American National Standards Institute Safety Code.

SYMBOLS

The following symbols are found throughout this Maintenance & Parts Manual to alert the reader to the relative danger that may result from non-observance.



This indicates a situation in which a hazard is imminent and will result in a high probability of serious injury or death.



This indicates a potentially hazardous situation, which could result in minor to moderate injury.



CAUTION

This indicates a potentially hazardous situation or unsafe practice which could result in product or property damaged.



IMPORTANT

This symbol indicates a general statement to assist the user in the operation or maintenance of the equipment.

TABLE OF CONTENTS

SECTION		PAGE
I.	Introduction	1
II.	Primary Components	2
III.	Frame Components	3
IV.	Air Routing Components	4
V.	Wheel, Lift & Pivot Components	5
VI.	ID & Caution Labels	6
VII.	Lift Cylinder Controls	7
VIII.	Control Components	8
IX.	Removing Impactor f/ Cart Frame	9
X.	Disassembling the Impactor	11
XI.	Parts Inspection	13
XII.	Reassembling the Impactor	17
XIII.	Impactor Exploded View	20
XIV.	Throttle Valve Exploded View	22
XV.	Fasteners	23
XVI.	Lubricator Components*	24
XVII.	Kits & Assemblies	25

***Only applicable to units purchased before 2017**

I. INTRODUCTION

Forward

This manual contains important information to help you properly operate and maintain your Gate Opener for maximum performance, economy, and safety. We recommend that you study its contents thoroughly before repairing or performing maintenance. By carrying out the recommended maintenance and repair procedures you will experience long, dependable, and safe service. After you have completely familiarized yourself with the contents of this manual, we recommend that you carefully file it for future reference.

Warning Labels

The warning labels found on this Gate Opener are an essential part of this product. Labels should not be removed. Labels should be checked periodically for legibility. Replace labels when missing or when the information can no longer be read. Replacement labels can be ordered as any spare part.



CAUTION

If not properly maintained the use of all mechanical equipment presents the possibility of personal injury or property damage. Before use, all persons who will operate or maintain the Gate Opener should read this manual thoroughly. For safe, dependable, and economical performance, follow all instructions and recommendations contained herein. It is also important to retain this manual for future use.

Storage

If it becomes necessary to store the Gate Opener for an extended period (more than 2-weeks), it should receive a generous amount of lubrication at that time, and again when returned to service. The Gate Opener should be stored in a clean and dry environment.

II. PRIMARY COMPONENTS

FRAME KIT
Includes all components except
Prepared Driver, Drive Fitting and
Throttle Valve

PN: 33-30052

**THROTTLE VALVE
ASSEMBLY**
PN: 32-50015



DRIVE FITTING
PN: 33-01410

Includes:

RETAINER PIN
PN: 32-50124

O-RING
PN: 32-50000

PREPARED DRIVER
PN: 33-20066

WORKMASTER

PH: 267.350.2809

III. FRAME COMPONENTS

FRAME ASSEMBLY
PN: 33-20045
Includes: (1) Chassis; (1) Pivot Guard; (1) Toolbox; (2) Hub Sleeves

PIVOT GUARD
PN: 33-10101

FWD/REV LEVER ASSEMBLY
PN: 32-50013

TOOLBOX
PN: 33-10105

HUB SLEEVE
PN: 33-20051



IV. AIR ROUTING COMPONENTS

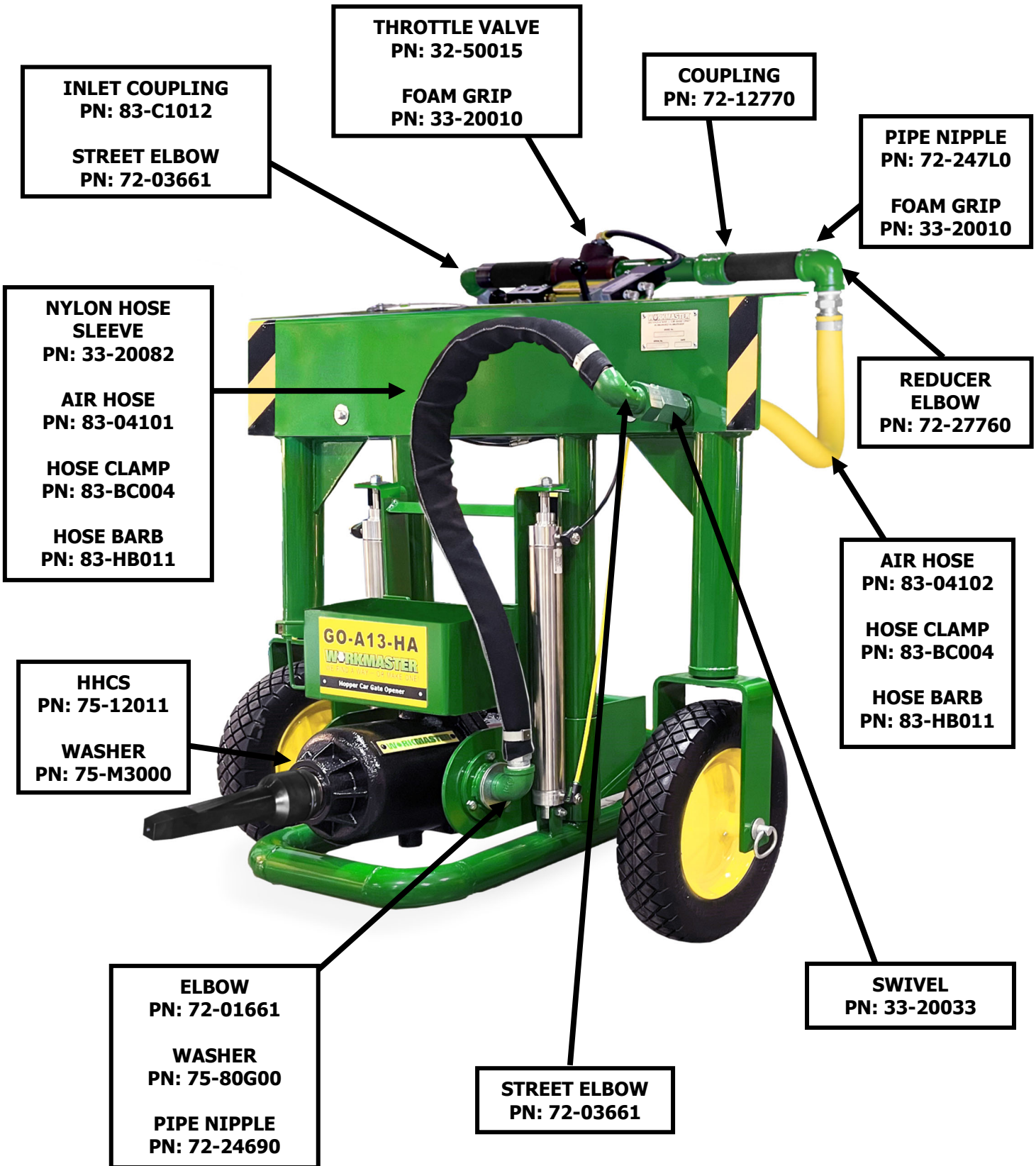

WORKMASTER

PH: 267.350.2809

V. WHEEL & PIVOT COMPONENTS

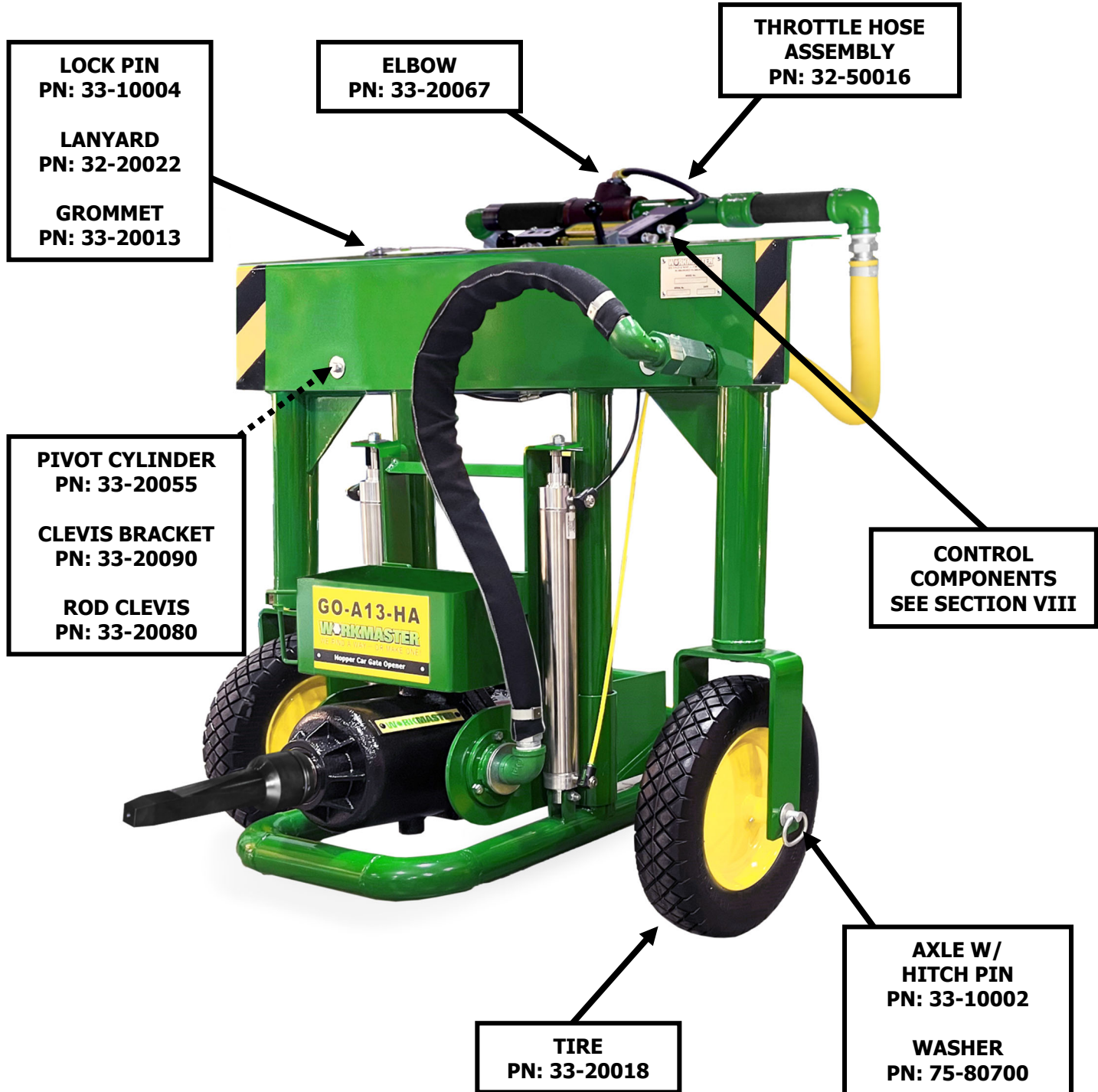

VI. ID & CAUTION LABELS

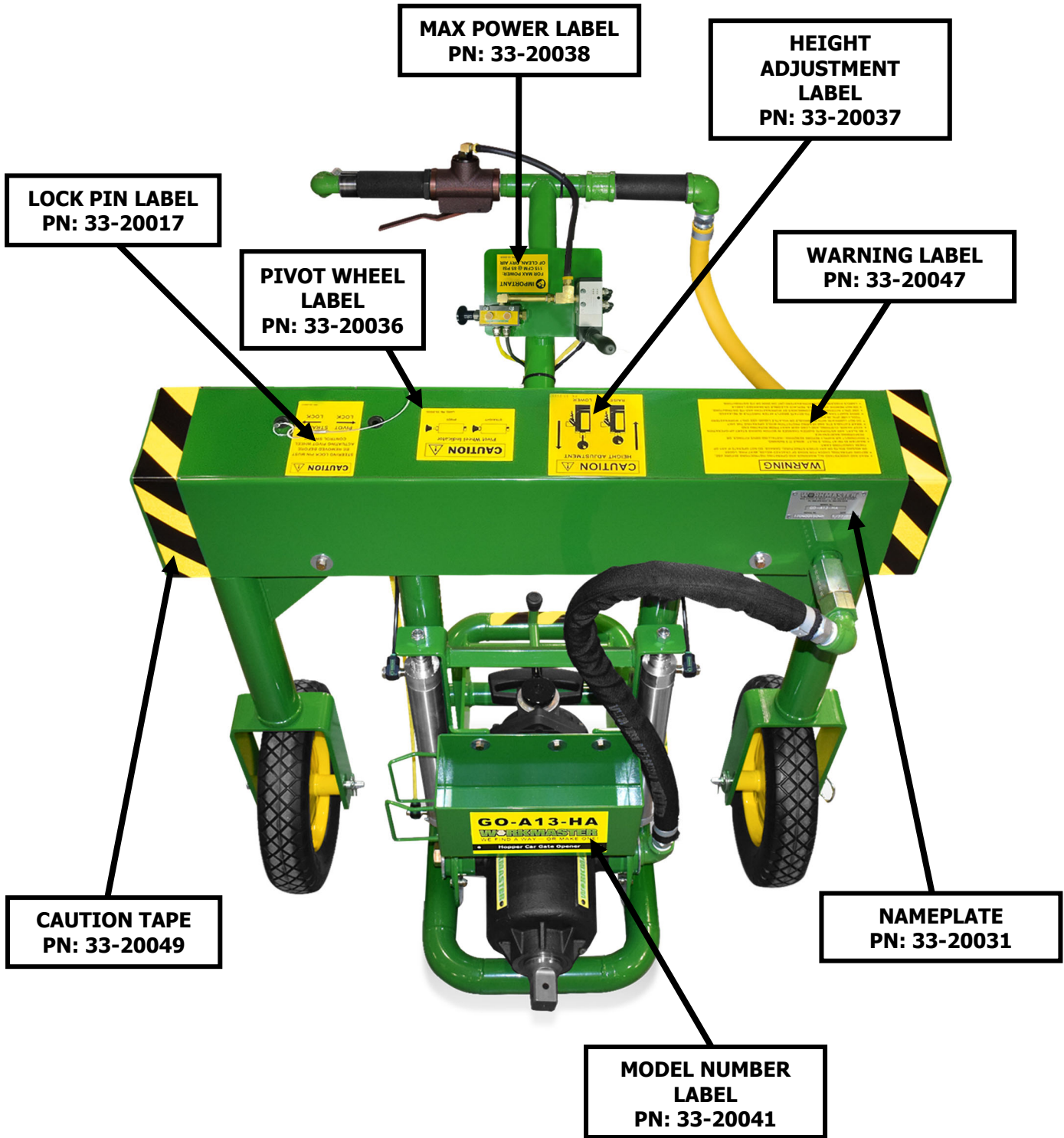

VII. LIFT CYLINDER CONTROLS

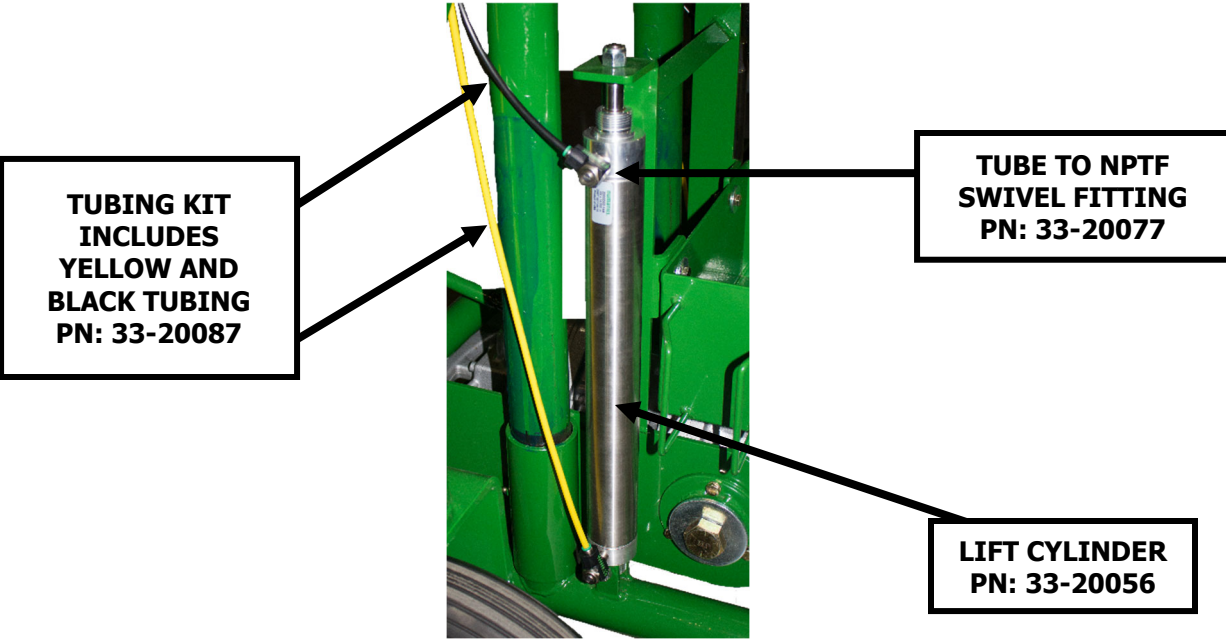
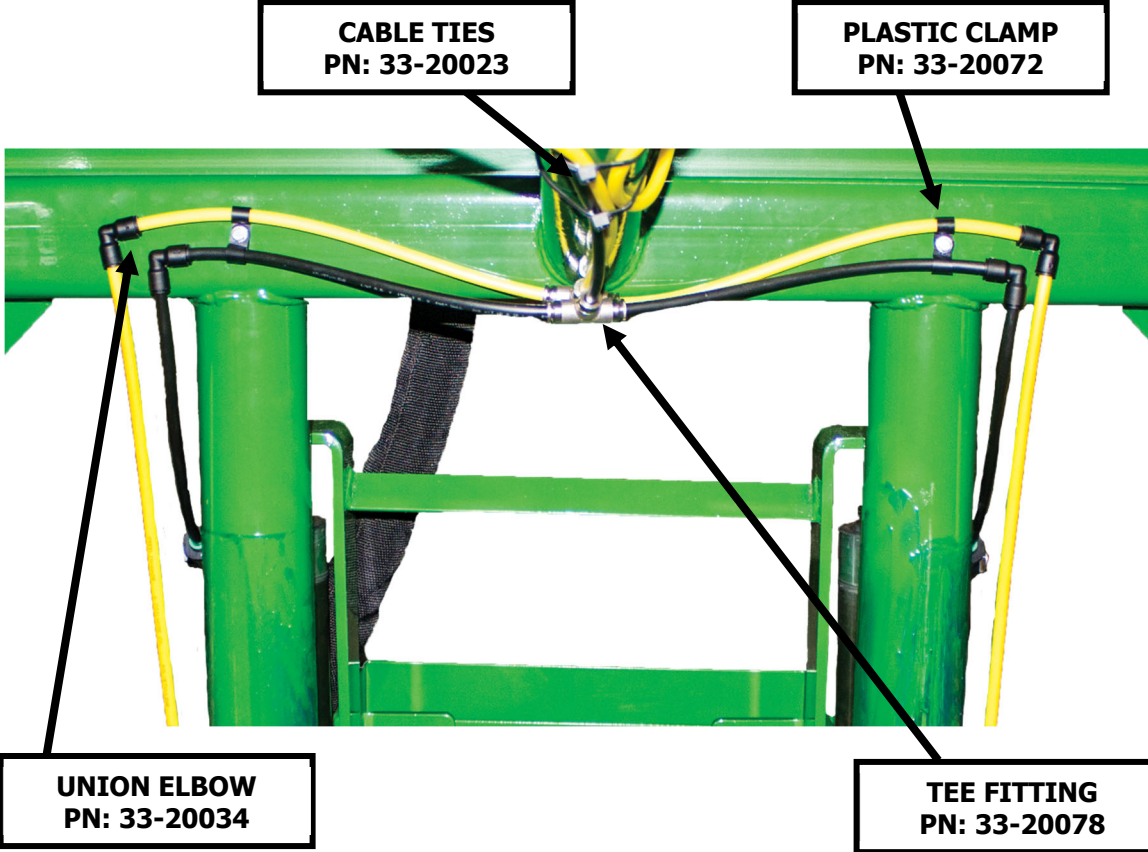

VIII. CONTROL COMPONENTS

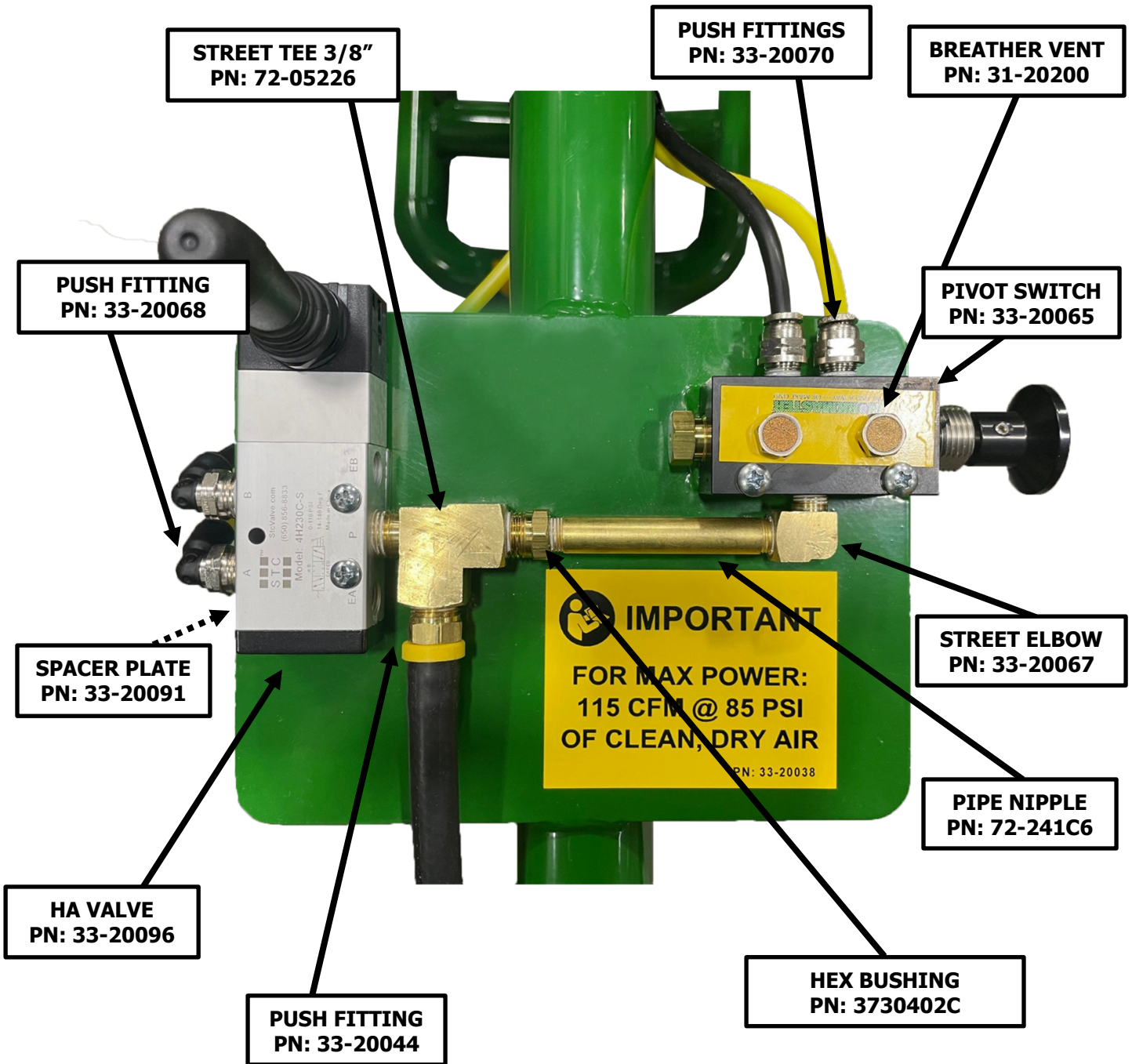

IX. REMOVING IMPACTOR F/ CART FRAME

To service the Impactor, it is necessary to remove the Impactor from the Rolling Cart. The following Instructions cover the complete and correct method of performing this operation refer to **SECTION XIII: Impactor Exploded View**.



IMPORTANT

These Instructions detail complete repair of the Impactor and its component parts. Some assemblies or components do not require tear-down inspection and repair. Overall condition of the Impactor will allow mechanic discretion on extent of repair.

1. Disconnect air supply from Throttle Valve.
2. Remove/cut-out Air Hose assembly at Air Inlet of Impactor.
3. Remove Nipple, Washer, Elbow and Hose Barb from the Impactor's Air Inlet boss.
4. Disconnect Bolt and Washer on opposite side of the Impactor's Air Inlet.
5. Brace the Gate Opener's Frame and the front, under-side of Impactor with a wooden block or like support.



Support the 125 lb. Impactor properly when removing it from the Frame. Failure to properly support the Impactor could result in injury.

6. Remove the six (6) 5/16" Cap Screws, Lock Washers, and Hex Nuts from the left and right Hub Sleeves.

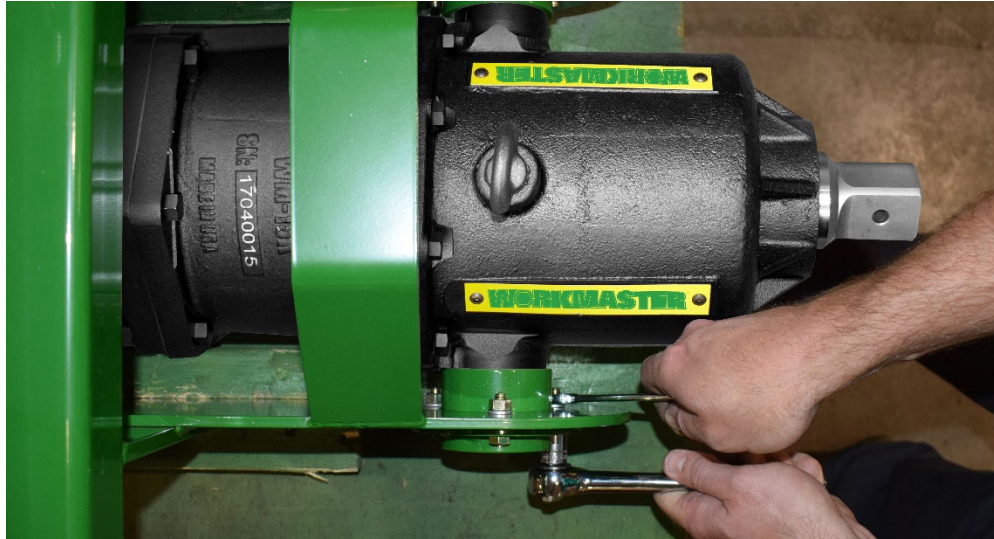

7. CAREFULLY remove Hub Sleeves, one at a time, from the Frame.
8. The Impactor can now be moved to a clean, sturdy workbench to be disassembled for required maintenance and/or repair.



IMPORTANT

To reinstall Impactor into Cart Frame, reverse the above procedure making sure the Impactor's Head Handle is positioned between the Frame's rear parallel Tubes.

X. DISASSEMBLING THE IMPACTOR

To disassemble the Impactor, refer to **Section XIII: Impactor Exploded View** while completing the following steps:

1. Remove six (6) Bolts [21] from Head Cover [33] and Motor Casing [20].
2. Separate Head Cover [33] from Motor Casing [20].
3. Remove eight (8) Bolts [2] from Hammer Casing [1] and Motor Casing [20].
4. Separate Hammer Casing [1] from Motor Casing [20] and Separator [19]. (Cone Bearing [18] and Anvil Rear Spacer [17] can be easily removed at this point.)
5. Remove internal parts from Hammer Casing [1].
6. With a soft face hammer, tap spline end of Rotor [27], until Rotor and Cylinder Plate [26] with Ball Bearing [25] and Notch Key [31] are free of Motor Casing [20].
7. With Arbor Press or similar, remove Rotor [27] from Cylinder Plate [26] and remove all nine (9) Rotor Blades [28] from Rotor.
8. CAREFULLY remove the Press Fit Ball Bearing [25] from Cylinder Plate [26].



IMPORTANT

If Cylinder [29] or Cylinder Plate [26] show signs of wear (rust, scoring, etc) Motor Casing [20] may need to be heated for Cylinder and Plate removal.

9. Remove Reverse Valve [35], by completely removing Reverse Lever Set Screw [39] from Reverse Lever [36].



IMPORTANT

It may be necessary to apply heat to the Reverse Lever [36] as Loctite adhesive is used to secure the Reverse Lever Set Screw [39].

- 10.** Remove Reverse Valve Cover [34] from Head Cover [33] (heat may need to be applied). Reverse Valve [35] can only be removed from Reverse Valve Bushing [41] in one direction.
- 11.** Remove Reverse Valve Spacer [42] and Reverse Valve O-ring [43].



IMPORTANT

For Technical Support call our Authorized Service Center AIRMATIC 215.333.5600.

XI. PARTS INSPECTIONS

When the **GO-A13-HA** Opener is in-for-maintenance and the Rolling Cart and Impactor have been disassembled (partial or complete), the components should be cleaned and inspected for wear before lubricating and reassembly of the Opener. Proper maintenance of equipment often depends upon the ability of a service technician to determine whether a part or assembly is worn to the point where it should be replaced. The following information is intended to help the service technician make this decision.



IMPORTANT

The components should be cleaned and inspected for wear or damage before lubricating and reassembly of the Opener.

Rebuild Kit (PN: 32-50010)				Repair Kit (PN: 32-50020)			
Item #	Part #	Description	Qty	Item #	Part #	Description	Qty
28	33-20121	Rotor Blade	9	28	33-20121	Rotor Blade	9
7	33-20136	Front Gasket	2	7	33-20136	Front Gasket	2
32	33-20135	Rear Gasket	1	32	33-20135	Rear Gasket	1
				25	33-20154	Cylinder Plate Bearing	2
				18	33-20155	Anvil Cone Bearing	1
				n/a	36-10605	Grease	2

1. The **CYLINDER [29]** is a sleeve that has been hardened, ground, and honed to close tolerance. It includes a series of slots or holes in the wall for porting the air to the Blades and exhausting it to atmosphere. Examine the Cylinder on the inside diameter for rough circular grooves. If such grooves are more than .005" deep, replace the Cylinder. Such grooves are usually caused by foreign matter in the airline.



IMPORTANT

Installation of an air filter/dryer in the air supply line is the best method for reducing grooving and scoring of the cylinder. PN: 82-10420 is recommended.

2. A badly scored Cylinder cannot be restored to usefulness by honing. Enlarging the inside diameter widens the seal point between the Rotor and Cylinder to a degree that will hinder the operation of the motor and will result in loss of speed and power.
3. Minor scoring and rust can be removed from the inside the Cylinder by using a Flybur Tool. This tool can be made from a slotted piece of metal dowel rod and a piece of 150 grit abrasive mounted in a small air or electric drill. If scoring cannot be removed with a light application of this tool, the Cylinder should be replaced.
4. The **ROTOR [27]** is the rotating member of the motor that transmits the torque produced by the Blades. It is machined of heat-treated steel and then ground to precise dimensions. Slots are milled in the body to accept the Blades. The front-end of the Rotor Spindle is splined for driving the **HAMMER CAM [16]**. Examine all surfaces of the Rotor for roughness and smooth them with an India Stone if necessary. Normally, there should be no noticeable wear on these faces since the Rotor is .003" (approx.) shorter than the Cylinder. Inspect the Blade slots for wear or burrs. A new Blade should move in and out of the slot freely. If necessary, use a honing stone to break away any sharp edges found on the corners of the slots of the Rotor. Examine the spline or gear teeth at the driving end. If they have become so worn that a step can be seen next to mating surfaces, then the Rotor should be replaced.
5. The **CYLINDER PLATES [26]** are machined from bearing bronze. They provide support to the Front and Rear Bearings and enclose the Cylinder ends. The Ball Bearings are in each Cylinder Plate and support the Rotor. If the face of the Front or Rear End Plate shows wear greater than a depth of .005" (or if Cylinder Plate is cracked) it should be replaced. Such wear is usually caused by dirty or wet air supply. Light score marks can often be lapped out with a 150-grit abrasive cloth on a flat surface plate.

6. The **CYLINDER PLATE BEARINGS [25]** provide a low friction support medium for the Rotor. To check the condition of a Bearing, hold the inner race and rotate the outer race by hand. If rough movement or substantial side play are detected, replace the Bearing. It is also possible to compare a used Bearing with a new one to detect the amount of wear.



IMPORTANT

Open type bearings in good condition may be washed in a fresh, clean solvent and then re-packed with a good quality bearing grease such as MOBIL DELVAC™ Xtreme Grease PN: 36-10605).

7. The **ROTOR BLADES [28]** are the most frequently replaced part since they are subjected to a high degree of movement, stress, and friction. The Blades are machined from a fibrous form of laminated phenolic. By means of various treatments, Blades are stabilized so that they can withstand a wide latitude of temperature, humidity, water, and oil. They are almost immune to warpage. All such characteristics are necessary to the smooth cycling action of the Blades as they move in and out of the Rotor slot. When the motor is running at regular speed, the Rotor Blades will be in continuous and forceful contact with the cylinder wall. In this powerful rotation each Rotor Blade can develop a thrust of over 6 lbs. At such pressures, any foreign material caught between the outer edge of the Blade, and cylinder wall can cause wear, scoring, and possible breakage. An air filter can help remove such harmful material, and a Lubricator will provide a thin oil film between the edge of the blade and the cylinder wall. This provides a better pressure seal and lessens the friction and wear.

If the Blade loses 20% or more of its width, or when, in the Rotor slot, it is worn 3/16" or more below the OD of the Rotor, the Blades must be replaced.



IMPORTANT

Width and height can be checked by comparing the old blades with a new one.

Blades narrowed from wear will eventually tilt at the edge of the Rotor slot, and this will create a groove mark on the side of the Blade. The groove mark will then deepen enough to cause the Blade to break or bind on the edge of the slot. Blade breakage can cause severe damage to the interior of the Cylinder. A Blade that binds on the edge of the slot will stall the motor and keep it from moving.

Rotor Blades found to be within wear limits may be cleaned by a simple lapping operation on each side and edge. Place a piece of 400 grit waterproof sandpaper or fine Emery Cloth on a flat surface and lightly lap each side of the Blade. This will clean the Blade but will not remove enough of the material to affect the overall performance of the Opener.



IMPORTANT

New Rotor Blades should also be lightly lapped before installing in Rotor to ensure that the Blades will move freely in the rotor slots.

It is good practice to replace the Blades each time the Impactor is disassembled for maintenance or repair. Routine replacement avoids the high cost of downtime caused by tool breakdown.

8. After the parts have been cleaned, inspected or, when needed, replaced, they should be wiped down with high quality air tool oil like **WORKMASTER Tool Lube** (PN: 36-21010) included in your purchase. The addition of the oil leaves a rust or moisture preventive film on the parts.
9. The **REAR GASKET [32]** and **FRONT GASKET [7]** should be inspected for wear and distortion.



IMPORTANT

It is good practice to replace the Front and Rear Gasket each time the Impactor is disassembled for maintenance or repair.

- 10.** The TWIN HAMMER MECHANISM of the Impactor is a highly effective design that delivers more power per pound and is less sensitive to air pressure fluctuations than any other design. Two Hammers strike instantaneous balanced blows to the Anvil's lobes generating powerful torque with minimal vibration.

To maintain this smooth balanced blow, particular attention must be given to the inspection of the striking faces of both **HAMMERS [15]** and to the lobes of the **ANVIL [10]**. If chipped, flattened or grooved surfaces are detected on either of the Hammers or the Anvil's lobes replace both the Hammers and the Anvil. The use of worn Hammers with a new Anvil, or vice-versa, will cause rapid wear of the new part.

- 11.** The **ANVIL [10]** accepts and transmits the high torque of the Impact Mechanism to the slide gate's capstan barrel via the Tapered Drive Fitting. The Anvil should be inspected and checked on a regular basis. The edges of the Anvil's 1 ½" Sq Dr are subject to various types of wear – including: rounding, spalling, chipping, or cracking – usually due to the use of a Drive Fitting with a worn socket. When the Anvil is worn, the excessive play within the Drive Fitting will create further wear on the Anvil's Sq Dr and more rapid wear of the Drive Fitting resulting in reduced power transfer, and increased vibration and noise.

XII. REASSEMBLING THE IMPACTOR

Once the Impactor's internal components have been inspected, repaired, or replaced, the Impactor can be reassembled. The reassembly of the Impactor is essentially the disassembly instructions in reverse order.



IMPORTANT

Refer to **Section XIII: Impactor Exploded View** during reassembly.

1. Wash all parts thoroughly in fresh, clean solvent.
2. Replace Rear Gasket **[32]** and Front Gasket **[7]**.
3. Coat all parts with a light film of spindle oil or air tool oil.
4. Clean and repack the Anvil Cone Bearing **[18]**, with grease (MOBIL DELVAC™ Xtreme Grease PN: 36-10605).
5. Make sure all air passages are free of any dirt or foreign matter.
6. Grease the Impact Mechanism **[10, 12, 13, 14, 15, 16]** heavily with a high-grade Impact Wrench Grease (MOBIL DELVAC™ Xtreme Grease PN: 36-10605, or Equal). Be sure to coat Hammer Cage Assembly completely and coat the inside wall of Hammer Casing **[1]** w/ a thick coating of grease as well.



IMPORTANT

DO NOT "pack" grease into Impact Section of Wrench. All parts must be coated in grease, but also able to move freely. "Packed" grease will inhibit free movement of components.

7. After the Impactor has been assembled, pour 2 oz. (6-8 squirts) of TOOL-LUBE air tool oil (supplied) in the Air Inlet to ensure immediate lubrication of the complete tool.

8. Before installing Impactor into Cart Frame, operate Impactor for a short period (3 to 5 minutes) of time to test for proper operation.
9. Check the free speed at the Anvil **[10]** with a tachometer. Speed is 1500 RPM (approx.) at 85 PSI using 150 CFM (approx.). The speed can be checked by using a tachometer (VIBRA-TAK slo-speed tachometer PN: 31-10001).



CAUTION

Never substitute wire, nails, welding rod, etc for retaining pins or fasteners because they are dangerous if thrown from the unit at free speed, or if the protruding nail or wire is accidentally grasped by the operator.

XIII. IMPACTOR EXPLODED VIEW

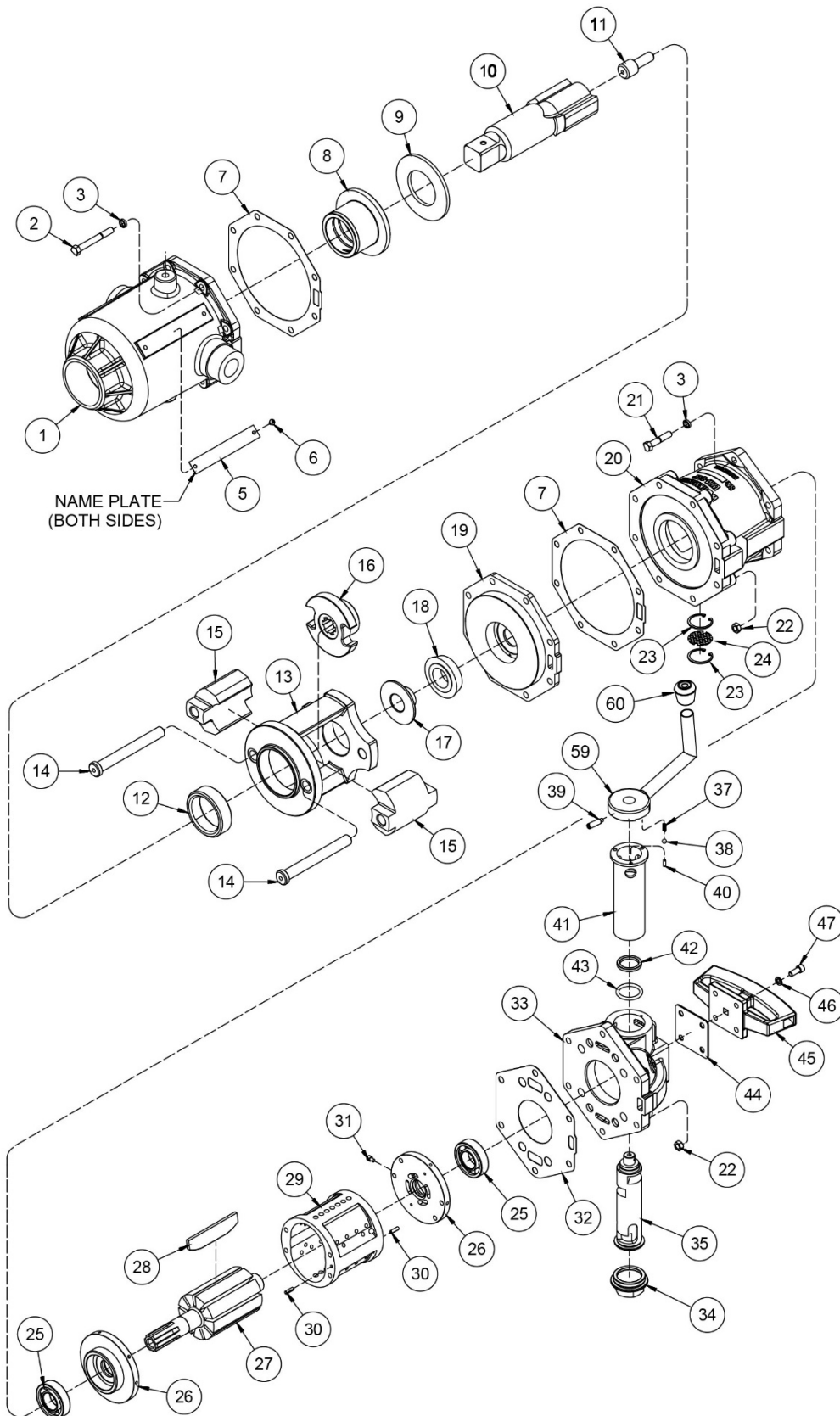

WORKMASTER

PH: 267.350.2809

PARTS LIST

Item #	Part#	Description	Qty		Item #	Part#	Description	Qty
1	33-20123	Hammer Casing	1		26	33-20118	Cylinder Plate	2
2	33-20140	Half Head Bolt	8		27	33-20120	Rotor	1
3	33-20143	Spring Washer	14		28	33-20121	Rotor Blade	9
5	33-20171	Name Plate	2		29	33-20119	Cylinder	1
6	33-20172	Fasteners for Name Plate	4		30	33-20150	Roll Pin	2
7	33-20136	Front Gasket	2		31	33-20152	Round Head Notch Key	1
8	33-20133	Anvil Bushing	1		32	33-20135	Rear Gasket	1
9	33-20132	Anvil Front Spacer	1		33	33-20101	Head Cover	1
10	33-20130	Anvil	1		34	33-20105	Reverse Valve Cover	1
11	33-20129	Pilot Pin	1		35	33-20102	Reverse Valve	1
12	33-20131	Hammer Cage Bushing	1		37	33-20145	Spring	1
13	33-20126	Hammer Cage	1		38	33-20153	Steel Ball	1
14	33-20128	Hammer Pin	2		39	33-20106	Reverse Lever Set Screw	1
15	33-20127	Hammer	2		40	33-20149	Roll Pin	1
16	33-20125	Hammer Cam	1		41	33-20103	Reverse Valve Bushing	1
17	33-20124	Anvil Rear Spacer	1		42	33-20160	Reverse Valve Spacer	1
18	33-20155	Anvil Cone Bearing	1		43	33-20157	Reverse Valve O-Ring	1
19	33-20122	Separator	1		44	33-20161	Handle Gasket	1
20	33-20117	Motor Casing	1		45	33-20100	Head Handle	1
21	33-20139	Half-Head Bolt	6		46	33-20142	Spring Washer	4
22	33-20144	Hex Nut	14		47	33-20178	Allen Head Bolt	4
23	33-20173	Retaining Ring	2		59	33-20176	F/R Lever	1
24	33-20174	Exhaust Screen	1		60	33-20074	Rubber Cap	1
25	33-20154	Cylinder Plate Bearing	2					

XIV. THROTTLE VALVE EXPLODED VIEW

Assembly Part #32-50015

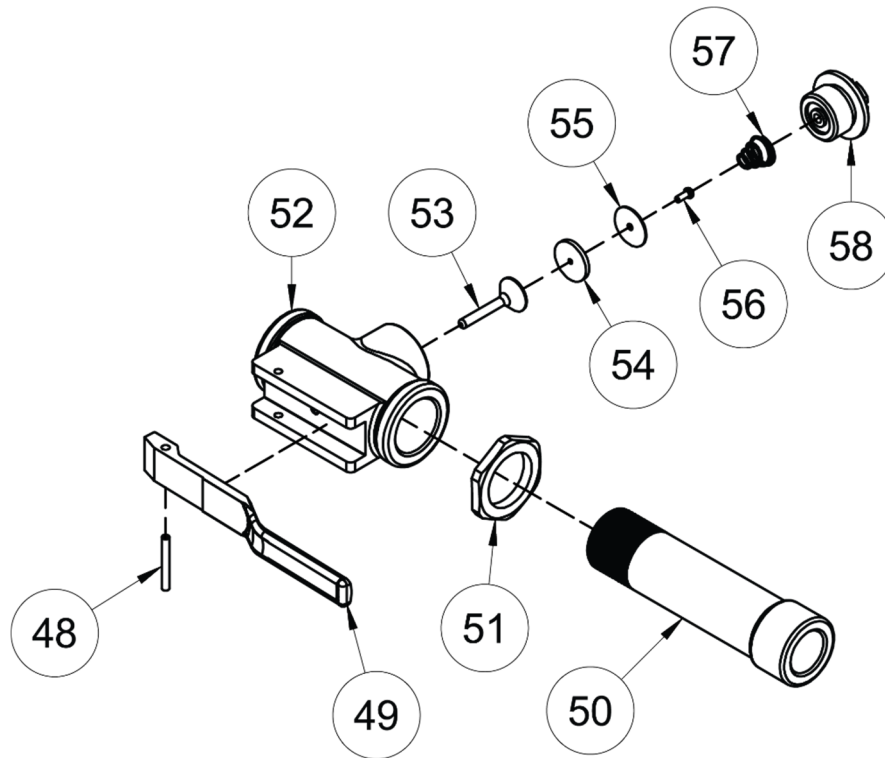

Item #	Part#	Description	Qty
48	33-20148	Roll Pin	1
49	33-20109	Throttle Trigger	1
50	33-20114	Valve Body Pipe	1
51	33-20116	Valve Body Nut	1
52	33-20107	Valve Body	1
53	33-20108	Valve	1
54	33-20137	Packing	1
55	33-20110	Valve Packing Spacer	1
56	33-20141	Screw	1
57	33-20147	Cone Spring	1
58	33-20111	Valve Cover	1

WORKMASTER

PH: 267.350.2809

XV. FASTENERS

PART #	DESCRIPTION	QTY	WHERE USED
75-30300	Hex Nut; 3/8-16	2	1
75-90300	Lock Washer; 3/8"	2	
75-10304	HHCS; 3/8-16 x 1"L	2	
75-OH100	IT Lock Washer; #10	2	2
7A-BB107	PPHMS; 10-24 x 1-3/4"L	2	
75-5B100	ESN; 10-24	2	
75-30200	Hex Nut; 5/16-18	6	3
75-90200	Lock Washer; 5/16"	6	
75-10204	HHCS; 5/16-18 x 1 "L	6	
75-30200	Hex Nut; 5/16-18	2	4
75-90200	Lock Washer; 5/16"	2	
75-10204	HHCS; 5/16-18 x 1 "L	2	
75-M0200	Fender Washer; 5/16"	2	
75-90200	Lock Washer; 5/16"	2	5
75-10204	HHCS; 5/16-18 x 1 "L	2	
75-M0200	Fender Washer; 5/16"	2	
75-12011	HHCS; 1-14 x 2-3/4"L	1	6
75-M3000	Fender Washer; 1"	1	
75-80G00	Flat Washer; 1-1/4"	1	
33-20027	Pop Rivet	4	7
75-10308	HHCS; 3/8-16 x 2"L	2	8
75-52300	ESN; 3/8-16	2	
75-51500	ESN; 1/2-20	2	9
75-Z1V07	PPHMS; 8-32 X 1-3/4	2	10
75-51V00	ESN; 8-32	2	

"WHERE USED" KEY:

1.	Pivot Cylinder to Chassis	6.	Trunnion Extensions
2.	Pivot Switch to Chassis	7.	Name Plate to Chassis
3.	Hub Sleeves to Chassis	8.	Lift Cylinders to Bottom Bracket
4.	Toolbox to Chassis	9.	Lift Cylinders to Top Bracket
5.	Pivot Guard to the Chassis	10.	Height Adjustment Valve

XVI. LUBRICATOR COMPONENTS*

*Only applicable to units purchased before 2017

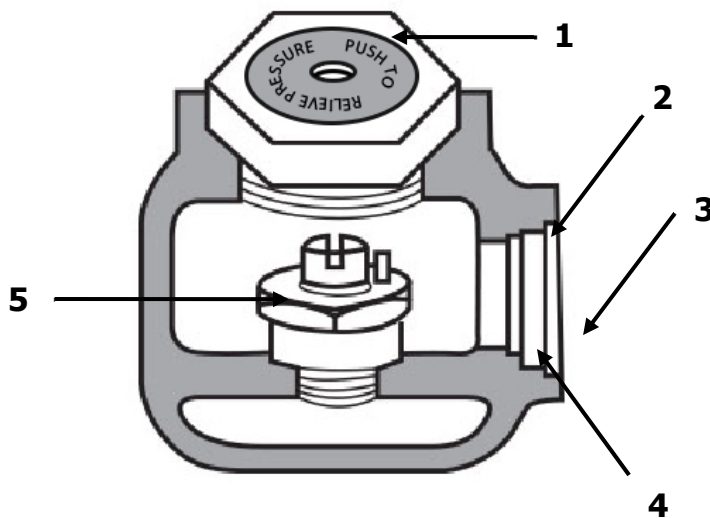
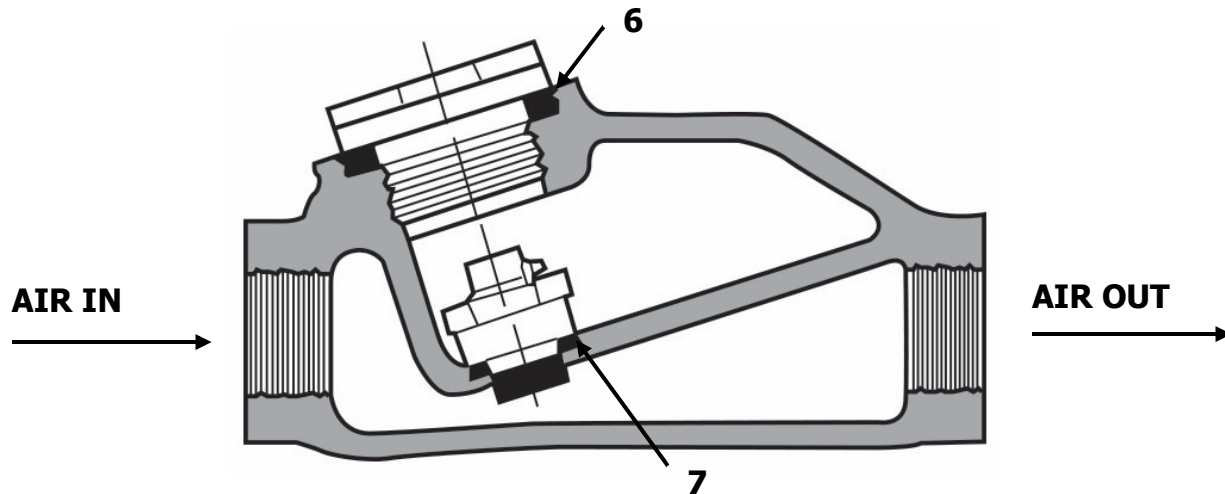

ITEM #	PART #	DESCRIPTION
1	82-40004-1	Pressure Relief Fill Cap
2	82-40004-2	Sight Disk
3	82-40004-3	Sight Disk Lock Nut
4	82-40004-4	Sight Disk Seal
5	82-40004-5	Oil Adjusting Valve Assy
6	82-40004-6	O-Ring f/ Fill Plug
7	82-40004-7	Valve Gasket

VIII. KITS & ASSEMBLIES

Rebuild Kit f/ GO-A8 & GO-A13 PN: 32-50010

A



28

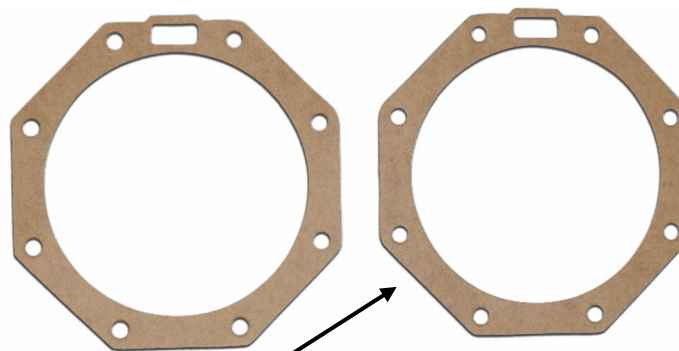

7

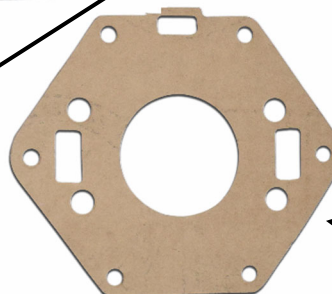

32

Item #	Part #	Description	Qty
A	10-00075	Rebuild Kit Manual	1
28	33-20121	Rotor Blade	9
7	33-20136	Front Gasket	2
32	33-20135	Rear Gasket	1

Repair Kit f/ GO-A8 & GO-A13 PN: 32-50020

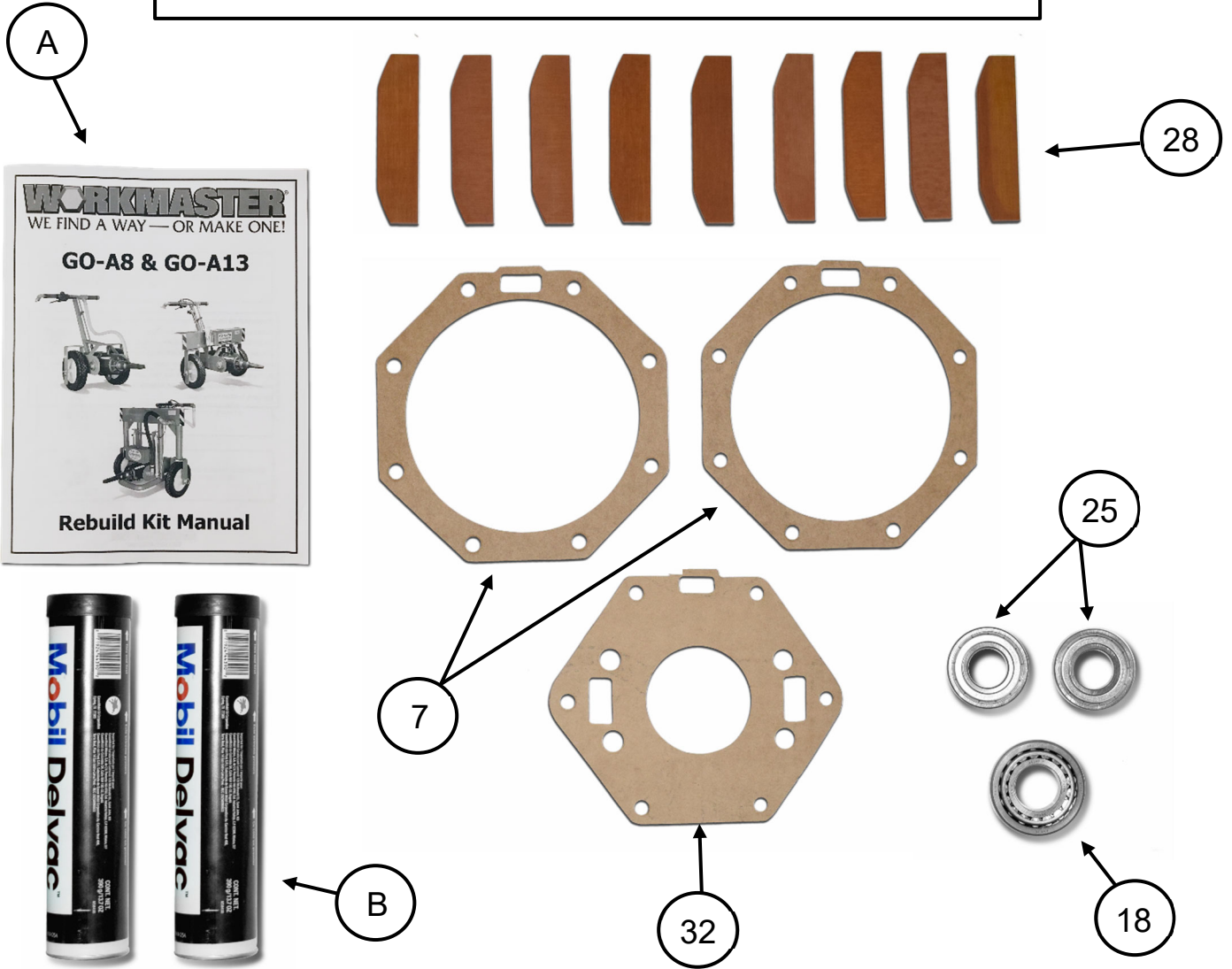

Item #	Part #	Description	Qty
A	10-00075	Rebuild Kit Manual	1
28	33-20121	Rotor Blade	9
7	33-20136	Front Gasket	2
25	33-20154	Cylinder Plate Bearing	2
18	33-20155	Anvil Cone Bearing	1
32	33-20135	Rear Gasket	1
B	36-10605	Grease, 13.7 oz	2

F/R Lever Assembly PN: 32-50013

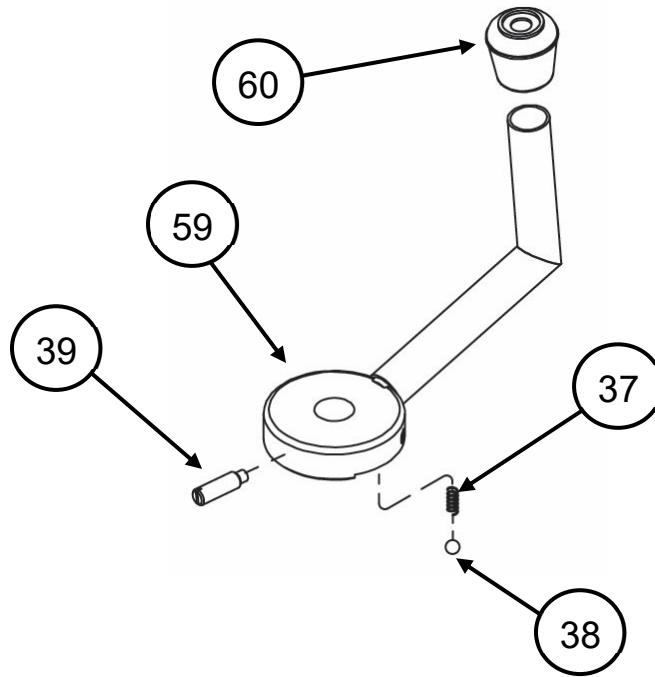

Item #	Part #	Description	Qty
37	33-20145	Spring	1
38	33-20153	Ball	1
39	33-20106	Set Screw	1
59	33-20176	F/R Lever	1
60	33-20074	Rubber Cap	1

**Head Cover Assembly
f/ GO-A13-HA
PN: 32-50030**

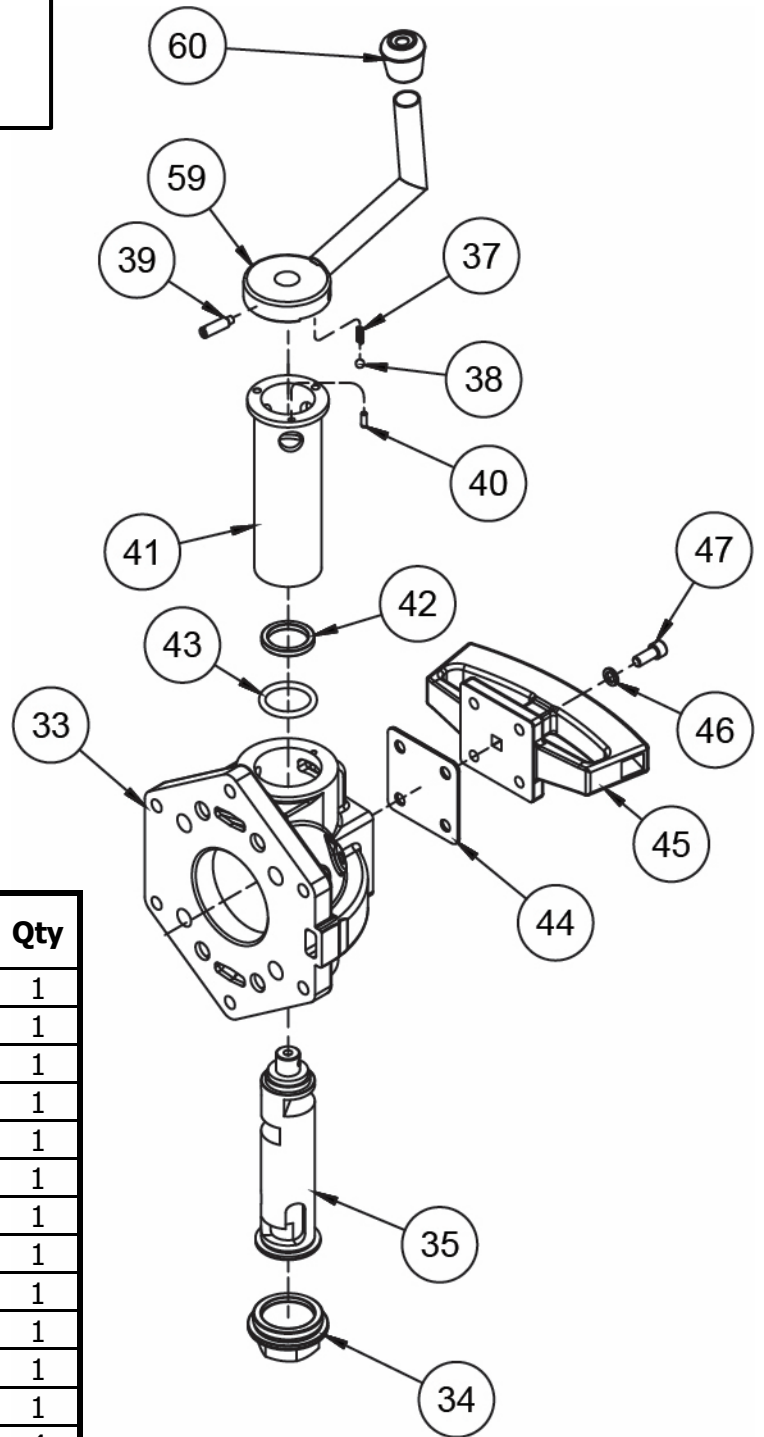

Item #	Part#	Description	Qty
33	33-20101	Head Cover	1
34	33-20105	Reverse Valve Cover	1
35	33-20102	Reverse Valve	1
37	33-20145	Spring	1
38	33-20153	Steel Ball	1
39	33-20106	Reverse Lever Set Screw	1
40	33-20149	Roll Pin	1
41	33-20103	Reverse Valve Bushing	1
42	33-20160	Reverse Valve Spacer	1
43	33-20157	Reverse Valve O-Ring	1
44	33-20161	Handle Gasket	1
45	33-20100	Head Handle	1
46	33-20142	Spring Washer	4
47	33-20178	Allen Head Bolt	4
59	33-20176	F/R Lever	1
60	33-20074	Rubber Cap	1

Ask about other Railcar Products



**Rail-Shaker
Piston Vibrator**



**CRT Turbine
Series Vibrator**



**CRR Roller
Series Vibrator**

A powerful boost for rail car unloading.